

CE REV 000A

Quick®

High Quality Nautical Equipment

STERN THRUSTER

STERN TUNNEL

140 - 185 - 250 - 300



IT Manuale d'installazione

GB Installation's Manual

ELICHE DI POPPA

STERN THRUSTERS



Please follow the instructions carefully, and make sure that all checkpoints are carefully controlled.

1 Make sure that there are enough space both inside and outside the transom of the boat (see FIG 1).

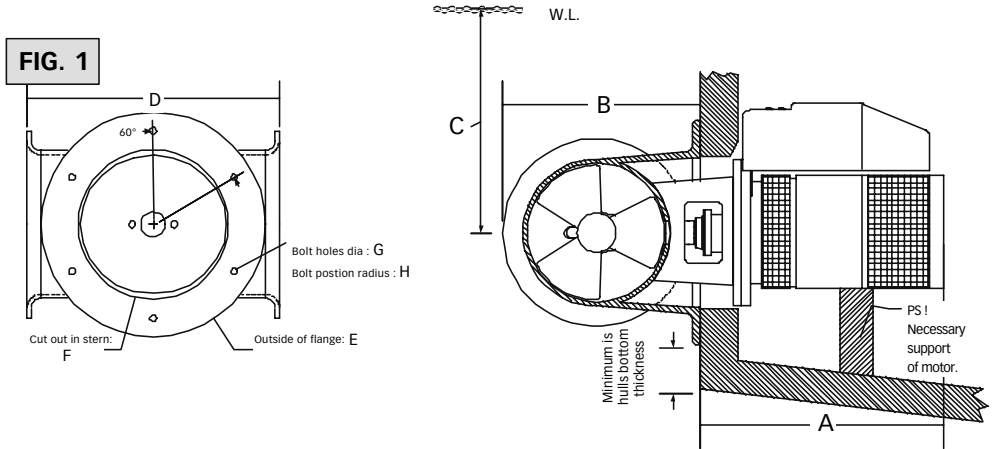

Modelli Models	BTQ 140-30	BTQ 140-40	BTQ 185-55	BTQ 185-75	BTQ 185-95	BTQ 250-140	BTQ 250-240	BTQ 300-250	BTQ 300-270
Tipo Elica Propulsion system	Elica singola Single propeller	Elica singola Single propeller	Elica singola Single propeller	Elica singola Single propeller	Elica singola Single propeller	Elica doppia Double propeller	Elica doppia Double propeller	Elica doppia Double propeller	Elica doppia Double propeller
Ø Tunnel	140 mm (5,5")	140 mm (5,5")	185 mm (7,3")	185 mm (7,3")	185 mm (7,3")	250 mm (9,85")	250 mm (9,85")	300 mm (11,8")	300 mm (11,8")
A	240 mm	240 mm	285 mm	285 mm	335 mm	330 mm	410 mm	365 mm	425 mm
B	176 mm	176 mm	235 mm	235 mm	235 mm	325 mm	325 mm	380 mm	380 mm
C	130 mm	130 mm	170 mm	170 mm	170 mm	230 mm	230 mm	280 mm	280 mm
D	250 mm	250 mm	325 mm	325 mm	325 mm	420 mm	420 mm	490 mm	490 mm
E	250 mm	250 mm	300 mm	300 mm	300 mm	380 mm	380 mm	380 mm	380 mm
F	158 mm	158 mm	196 mm	196 mm	196 mm	255 mm	255 mm	255 mm	255 mm
G	9 mm	9 mm	10,5 mm	10,5 mm	10,5 mm	10,5 mm	10,5 mm	10,5 mm	10,5 mm
H	105 mm	105 mm	127,5 mm	127,5 mm	127,5 mm	160 mm	160 mm	160 mm	160 mm

Additional considerations for positioning of stern thruster.

- ☞ Make sure that the stern-tunnel does not disturb the waterflow under the hull.
- ☞ Ensure that when installed the thruster does not foul existing equipment inside the boat like steerage links etc.
- ☞ It is essential that the motor is supported so that the total weight is not on the tunnel alone.
- ☞ Make sure that the water flow from the thruster are not interferred to much by sterndrives, trimtabs etc. as this will reduce the thrust considerably.
- ☞ It is possible to mount the tunnel off the boat's centre line if necessary.
- ☞ If the stern thickness is too much for the thruster in question you can easily remove material in the necessary area to fit the thruster. The stern thickness even here will never have to be less than the max. measurement given as max. stern thickness.



BOLT ON INSTALLATION

- 2a Once the place for the installation has been decided, hold the tunnel in place in the horizontal position and mark the bolt holes. Remove the tunnel and it is then possible to calculate and mark the centre (see Fig. 1).
- 3a It is important that the tunnel flange sits flush on the transom. If this is not case, then the fitting area on the transom will have to be worked to ensure a snug fit. PS! Take care with grinders as it is very easy to remove to much fibreglass. At this time, cut out the centre hole and the transom to the same internal diameter as the tunnel flange and drill the bolt holes. Before actual fitting the stern tunnel, we recommend that the prepared area is sealed with a gelcoat or similar to ensure there is no water ingress.
- 4a Before fitting the tunnel to the transom, install the gear leg to the tunnel as described in the thruster installation manual. We recommend that you fit the oil feed pipe also before the tunnel is bolted to the transom. Special installation points described on page 7 of this manual.
- 5a When fitting the tunnel, ensure that there is ample sealant (Sikaflex or similar) in the sealing tracks of the tunnel flange and around the bolts to make a water tight fitting (see FIG. 2&3). Bolts, washers and nuts are not included as they will vary depending on the transom thickness. We recommend A4 stainless with A4 lock nuts and A4 washers of a large diameter on both outside and inside.
- 6a The electromotor must have a solid support so that the weight can not cause a twisting action on the tunnel (see FIG. 4).
- 7a Refer to the installation manual for the recommended thruster fitting.

FIG. 2

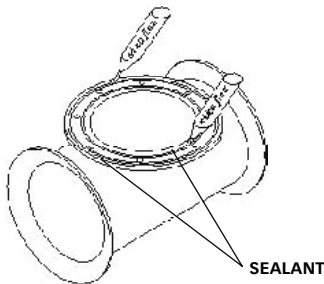

FIG. 3

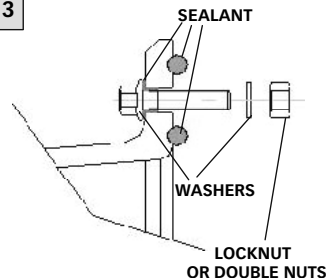
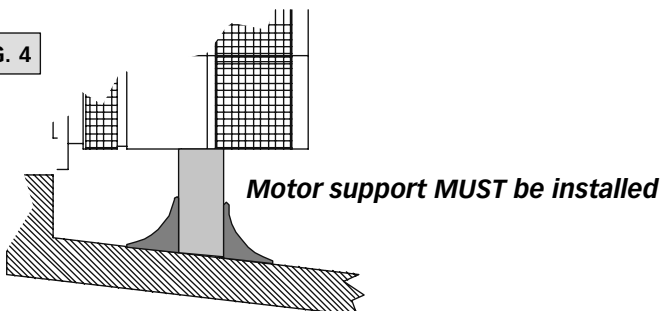

FIG. 4





THE STERN-THRUSTER MUST BE KEPT DRY AT ALL TIMES

It is very important that you do everything possible to ensure that the thruster stays dry at all times.

The electromotor and solenoid system is not to be considered as waterproof, and will be damaged if they keep getting wet (rust and corrosion). Therefore, the thrusters installation compartment must be kept dry at all times.

This is more difficult for a sternthruster installation than for a bowthruster installation as the sternthruster has to be fitted in the bilge at the stern of the boat. This is generally a "wet" area that must be transformed into a dry area.

IMPORTANT PRECAUTIONS!

- You must seal all drain holes going into the compartment of the thruster.
 - The surrounding compartments and any plates or compartments above must be drained in a good way to the bilge area in front of the thrusters installation compartment.
 - If the propeller shaft or other moving parts with a high possibility for leakage comes through the bottom of the boat in the same compartment where the thruster is placed, you must make a separate compartment for the thruster isolating it from these very normal and highly probable water leakages.
 - The rudder shaft entrances to the boat and its surroundings must be drained so that any water coming in here are drained to go into the compartment in front of the sternthruster compartment.
- It is also important to ensure that the sternthrusters installation compartment will not be were water runs if a self-draining system of the boat deck fails to operate properly.
- Generally, all possible actions should be taken to ensure that water leakages from sources that are likely to have water leakages are drained to prevent water from entering the stern-thruster compartment.
 - **We advice to install a self-activating bilge-pump, preferably with an alarm system, in the stern-thruster compartment. If you are not confident that you have been able to seal this comparmnet well, this pump is absolutely necessary.**
 - The control-cable system for the thruster must be installed so that atleast all junctions and connectors are kept dry at all times.
 - In the Sidepower sternthruster kit, there will be included a cable, so that electronic controlbox originally placed on the electromotor, can be fitted away from the thruster in a higher position securing that it will stay dry at all times, even if there are accidental leakages into the stern-thruster compartment. Please see instructions on the following pages of how to connect this. If you are installing a sternthruster without the special sternthruster tunnel available from Quick, this kit can be bought seperately.

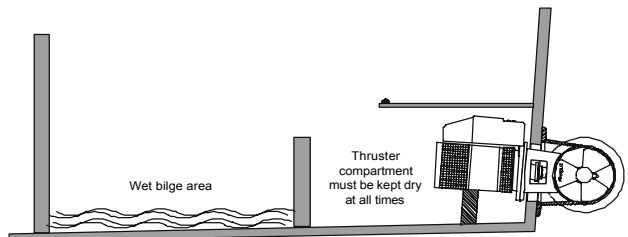
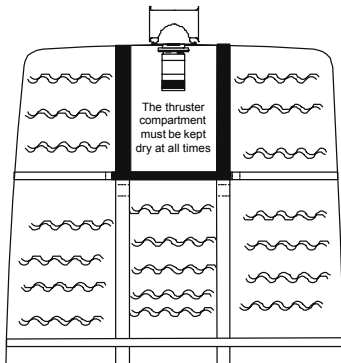



THE STERN-THRUSTER MUST BE KEPT DRY AT ALL TIMES

Description of illustrations:

A All draining holes or other openings from wet areas into the thruster installation compartment must be sealed.

B Originally non-sealed bulkhead

C Stringers in the boats length directions, normally there are drain holes through these from side-compartments.

D Plate above bilge where the steering system and other technical installations are often installed.

E Watertight bulkhead to engine room.

F Thruster

G Ensure there are draining holes in these positions to lead the water to the bilge to be pumpe out.

H Make anti drip edges on all surfaces above the thruster compartment to ensure that any water here will go via the drain holes and to the wet part of the bilge.

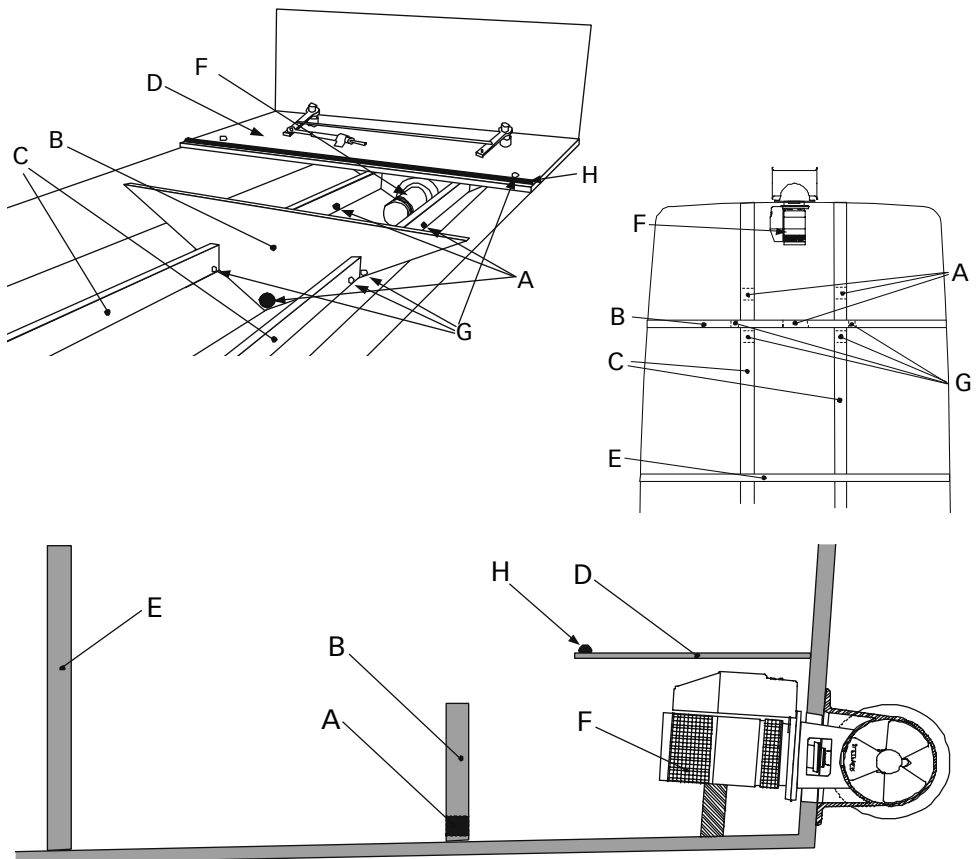

STERN THRUSTERS

140/185/250/300

R000A

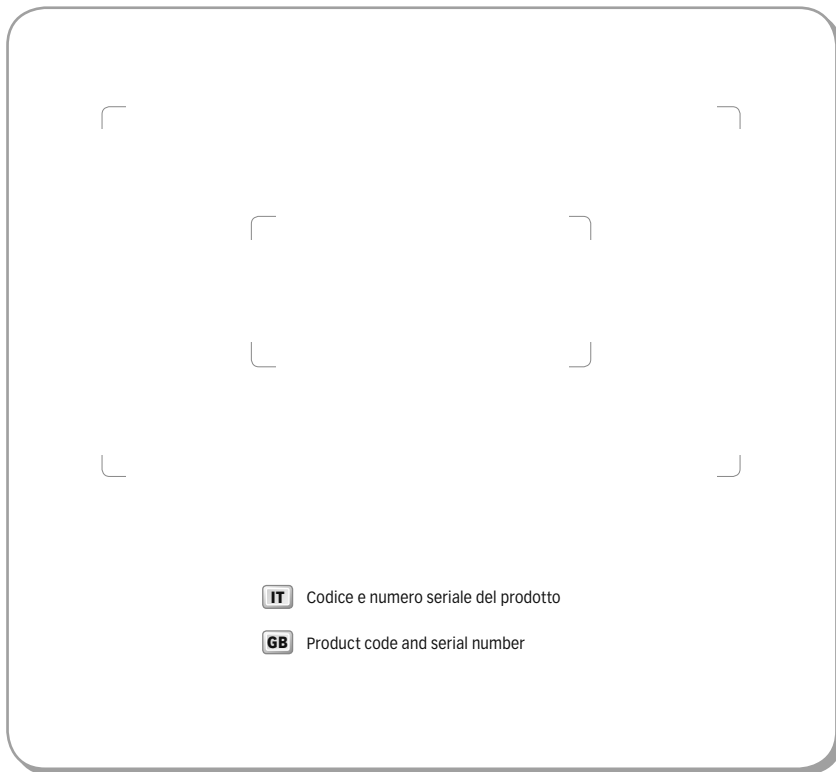

Quick[®]
Nautical Equipment

QUICK[®] SRL - Via Piangipane, 120/A - 48124 Piangipane (RAVENNA) - ITALY
Tel. +39.0544.415061 - Fax +39.0544.415047
www.quickitaly.com - E-mail: quick@quickitaly.com